



SPC-1503

15" XGA Full IP-65 Stainless Steel Chassis Fanless Touch Panel PC with Intel® 945GSE Solution



Features

- Water Proof Solution, Full IP-65 Rating
- Stainless and Aluminum Housings Chassis Design
- 5-wire Resistive Glass On Top Touch Panel PC
- Onboard Intel® Atom™ N270 1.6GHz CPU
- Intel® 945GSE/ ICH8-M Chipset
- Onboard 1GB DDR2 and One 200-pin DDR2 SODIMM Supports Up to 2GB DDR2 400/ 533
- Dual Gigabit Ethernet, Optional 2.5" HDD
- 1 CF, 1 COM, 2 USB, 1 Membrane Power Button
- Fanless & Single +12V Operation

Intel® ICH8-M	2 GbE	CF	1 COM	2 USB
Touch Screen	Fanless	IP65		

Specifications

Panel

• LCD Size	15", 4:3
• Display Type	XGA TFT
• Resolution	1024 x 768
• Pixel Pitch	0.297mm (H) x 0.297mm (V)
• Luminance	250nits (cd/m²)
• Contrast Ratio	500
• Viewing Angle	65 (U), 60 (D), 70 (L), 70 (R)
• Response Time	8ms
• Backlight	CCFL
• Touch Type	5-wire Resistive
• Touch Light Transmission	80%
• Touch Interface	USB

System

• Board	EBM-945GSE
• CPU	Onboard Intel® Atom™ N270 1.6GHz (2.5W)
• System Chipset	Intel® 945GSE/ ICH8-M
• I/O Chip	ITE IT8712F
• System Memory	Onboard 1GB DDR2 and One 200-pin DDR2 SODIMM Supports Up to 2GB DDR2 400/ 533 (1GB Per Bank)
• SSD	One CF Socket by IDE Secondary Slave Channel Supports Type I/II Compact Flash Card
• Hard Driver Bay	One 2.5" SATA HDD or Optional 44-pin Enhanced IDE HDD
• WiFi	Optional USB WiFi 802.11b/g
• Watchdog Timer	Reset: 1sec. ~ 255min. and 1sec. or 1min./step
• H/W Status Monitor	Monitoring System Temperature, Voltage with Auto Throttling Control
• Expansion	1 x Mini PCI, Optional 1 x Mini PCIe

Rear I/O

• Serial Port	1 x RS-232 (Water Proof, IP-67 Rating)
• Ethernet	2 x RJ-45 (Water Proof, IP-67 Rating)
• USB	2 x USB 2.0 (Water Proof, IP-67 Rating)
• Power Switch	1 x Membrane Power Button
• Power Input	1 x DC-in (Water Proof, IP-67 Rating)

Ethernet

• LAN Chip	Dual Realtek 8111C Gigabit Ethernet, Supports Wake on LAN
• Ethernet Interface	10/ 100/ 1000 Base-Tx Gigabit Ethernet Compatible

Mechanical & Environmental

• Color	Front & Rear Panel Silver
• Mounting	VESA/ Wall/ Stand 75mm x 75mm
• Power Input	100 ~ 250Vdc/ 47 ~ 63Hz
• Power Output	+12Vdc/ 5A (60W)
• Power Type	AT/ ATX
• Operating Temp.	0 ~ 40°C (32 ~ 104°F)
• Storage Temp.	-20 ~ 75°C (-4 ~ 167°F)
• Operating Humidity	5% ~ 90% Relative Humidity, Non-condensing
• Dimensions	370mm x 295mm x 60mm
• Weight	6.42Kgs

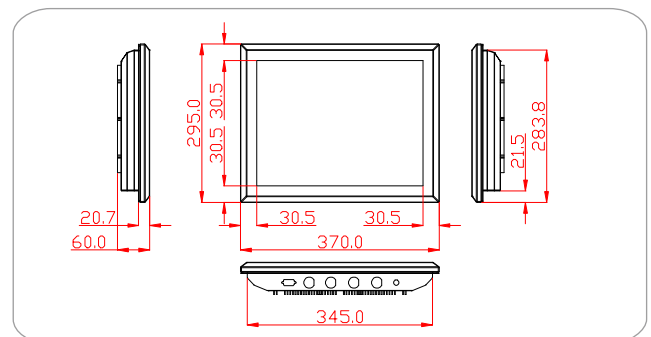

Ordering Information

- SPC-1503
15" XGA TFT Touch Panel PC with Intel® Atom™ N270 1.6 GHz CPU